

## **INTRODUCTION:**

The Ritchie MS-100 is a digital electronic heading sensor that will provide highly accurate heading information to navigational electronics. The MS-100 is available with various interfaces making it compatible with most autopilots, radars and navigation instruments. Simultaneously the sensor will drive Ritchie Magtronic Compass Displays and Interface Modules to form a complete heading display and distribution system based upon a single heading sensor.

## **INSTALLATION:**

The MS-100 is carefully calibrated at the factory. Since all compasses and magnetic heading sensors are subject to disruptive magnetic fields present on boats the following guidelines for locating the MS-100 should be followed in order to eliminate or minimize the effect of these interferences.

## **LOCATION:**

Two requirements must be met simultaneously in choosing the mounting location for your MS-100 heading sensor. The first is that the sensor must be located as far away from magnetic influences as possible. A minimum of three feet is recommended. There are two types of magnetic interference, fixed and variable. Variable sources of interference cause the most serious errors as they will change in time and cannot be easily compensated. Fixed sources of magnetic interference should also be avoided at the time of installation in order to optimize the performance of the sensor. Some examples of items which will cause magnetic influences are:

- LOUDSPEAKERS
- Electronic Equipment
- Horns
- VHF Radios, Microphones
- Engines, Electric Motors and Generators
- Magnetic Compasses
- Movable Metal Objects
- Wires Carrying High Current
- Battery Banks
- Refrigerators, Freezers, Ice makers, Dishwashers
- Galley Stoves, Trash Compactors, Washers and Dryers
- Air Conditioners
- Water Makers and Water Tanks
- Built in Vacuum Systems

Upon choosing a suitable location for the heading sensor the following guidelines should be followed:

- Use Only Non-Magnetic Hardware To Mount The Bracket
- The Top Of The Sensor (Label) Should Be Made Level Before Tightening The Thumbscrews.
- The Point On Top Of The Sensor Should Point Forward (Direction Of Travel)
- Tighten The Clamping Ring So That The Sensor Will Not Rotate

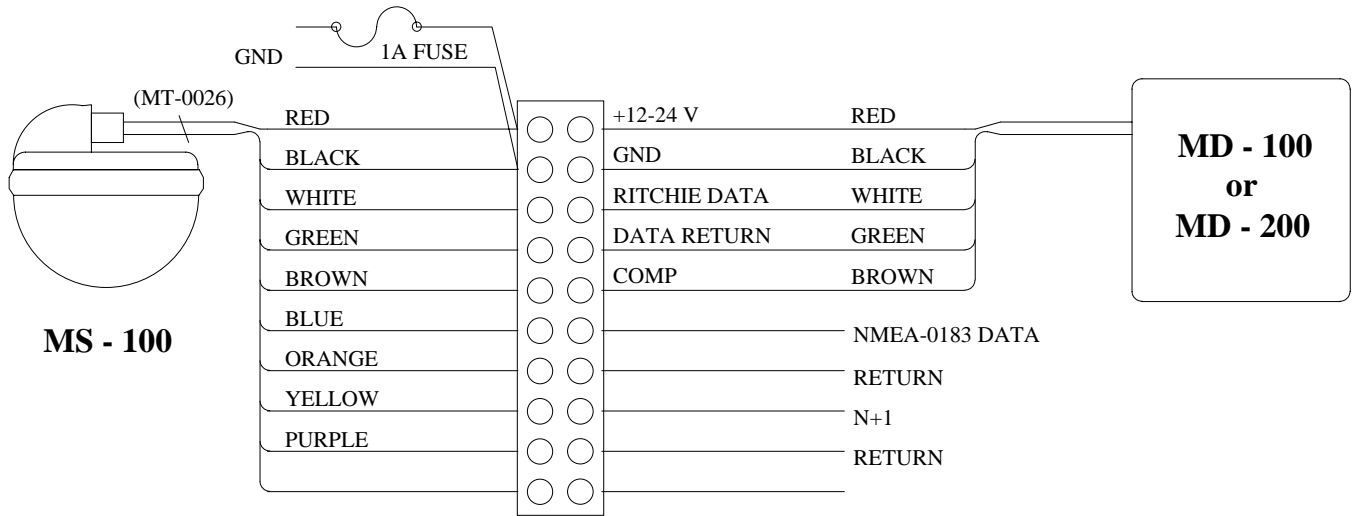

**MS - 100**

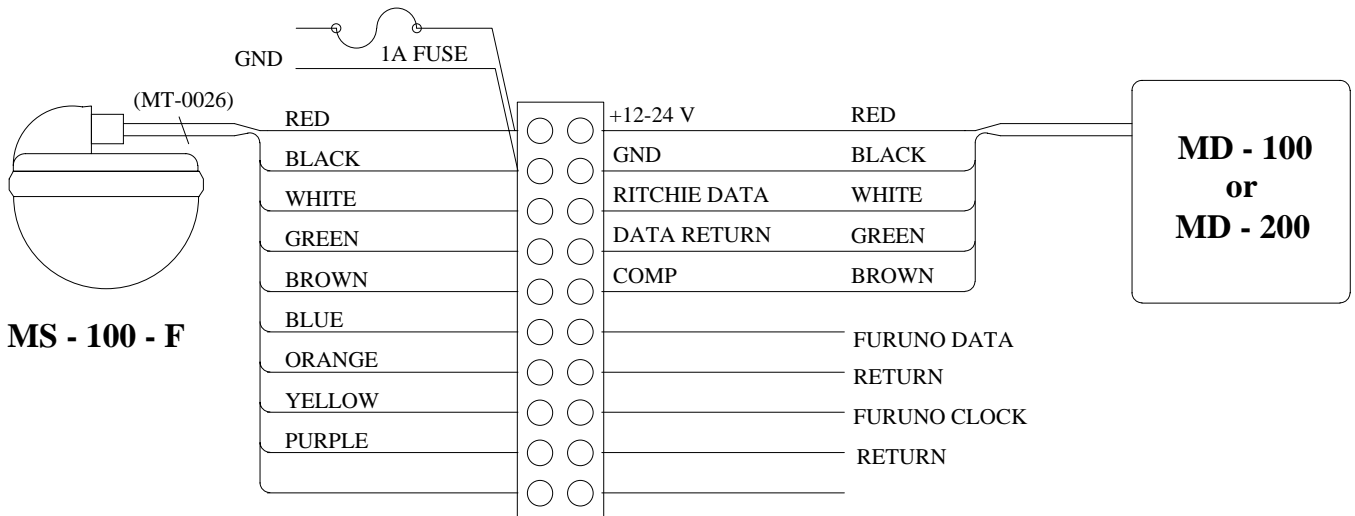

**MS - 100 - F**

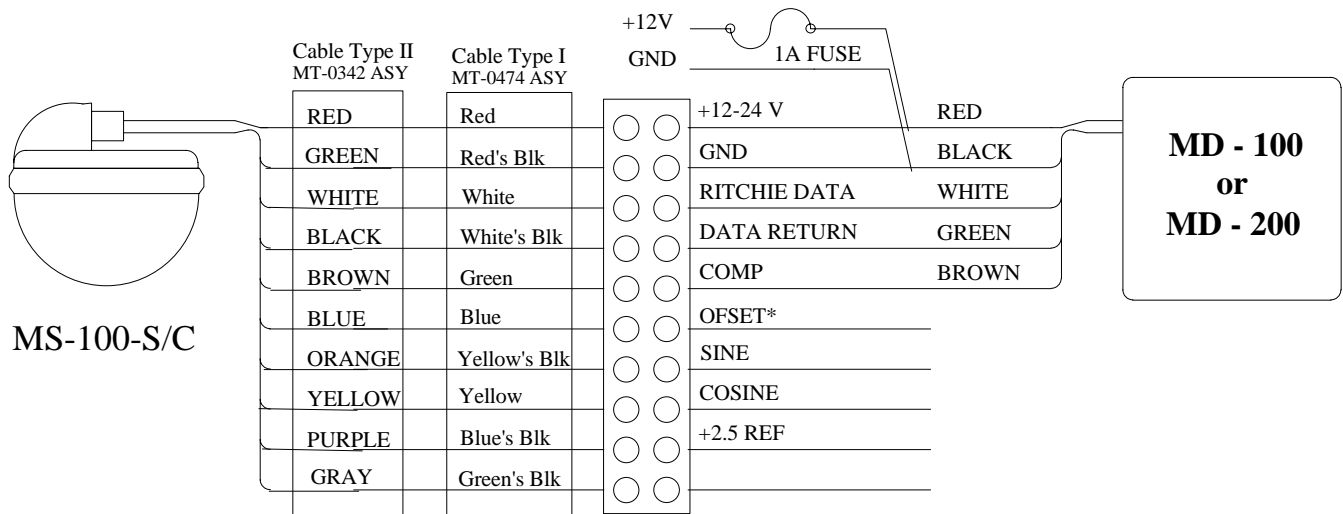

**MS-100-S/C**

**NOTE:** MS-100-S/C sensors are shipped with two types of cable. Before attempting to wire the sensor, identify your cable type and use the appropriate wiring diagram shown above.

**\*OFFSET:** Some Robertson Autopilots that provide both fluxgate and magnetic compass input ports exhibit discrepancies between the Ritchie and Robertson displays. These discrepancies are caused by an offset generated in the unused magnetic compass input port of the autopilot. By grounding the OFFSET (Blue Wire) line the sensor will automatically correct for these discrepancies.

## COMPENSATION:

Compensation is the procedure of adjusting a compass to compensate for errors in the displayed magnetic heading. These errors, commonly called deviations, are due to magnetic disturbances on the vessel. The MS-100 is equipped with automatic compensation software that will remove these deviations with the execution of the following simple procedure.

- 1) Perform the compensation in calm water.
- 2) The compensation procedure is initiated by grounding the BROWN wire in the wiring harness. This can be accomplished by connecting it to the BLACK wire for the duration of the procedure. Installing a switch between will greatly ease this portion of the procedure.
- 3) Ground the BROWN wire manually or via a switch. This connection must remain intact for the duration of step 4.
- 4) Rotate the vessel slowly through two complete turns. A slow steady turn in calm water will give the most accurate results. A good rate of turn is approximately (1-2) minutes per revolution.
- 5) Release the BROWN wire from ground by removing it from the BLACK wire or placing the switch in the OFF position.
- 6) Check the compass heading at the display against known headings to verify that the procedure was completed properly. If a constant error is found then rotate the sensor within it's clamping ring to remove the error.

Example: 2° on North, 92° on East, 182° on South, 272° on West  
(Rotate the sensor 2° Counter-Clockwise to Correct)  
(Rotate Sensor Clockwise for Negative Error)

If the heading shows no error when compared against correct reference headings, the compensation was completed successfully. Under certain conditions the software will sense undesirable conditions such as jarring or a reversal of direction and reject the compensation. In the event this occurs the procedure can be repeated beginning step 3.

- 7) After completing the procedure isolate the COMP wire so that it is not accidentally grounded during normal use. This is not necessary if the sensor is connected to a Ritchie display.

**It should be noted that all heading devices should be checked against known references or by a professional compass adjuster prior to their use for navigation.**