

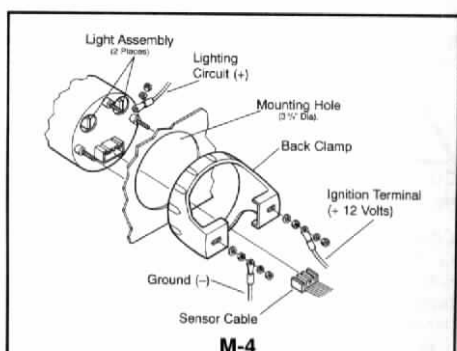

CAUTION

The Heading Sensors for all Electronic Compasses are vulnerable to magnetic interference which will produce errors (deviation). Heading Sensors should be compensated for permanent interference present on the vessel. Use the built-in Automatic Compensation System to correct for permanent interference. The Sensor should then be checked for accuracy prior to use for navigation. It is the responsibility of the Owner/Helmsman to keep the environment of the Sensor clear of objects that cause temporary magnetic interference such as: Tools, Portable Radios and Navigational Instruments, Beverage Cans, Fishing Tackle and any other metal objects.

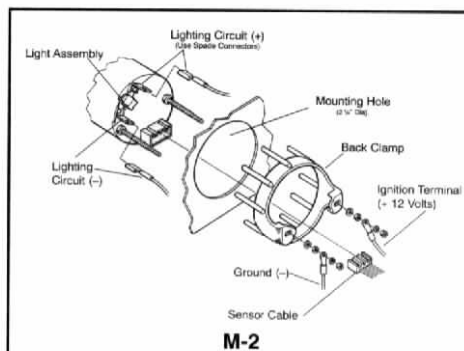

Instrument Location

Ritchie Gauge Mounted Electronic Compasses are designed for mounting in standard 2 1/8" or 3 3/8" Instrument Holes. If possible you should select a location that is directly in front of the helmsman and easily viewed while looking forward.



CAUTION

Disconnect the battery during installation. Tighten nuts on the back clamp only slightly more than you can tighten with your fingers. Six inch-pounds of torque is sufficient. Over tightening could result in damage to the instrument and may void your warranty.

1. Mounting requires the use of an existing instrument hole of the appropriate size or the drilling of either a 2 1/8" (5.4cm) diameter or a 3-3/8" (8.5cm) diameter hole in the dash, instrument panel or bulkhead. See Mounting Hole diameter in the diagram above for your model. Mount the compass with the back clamp and nuts supplied.
2. Be certain to use stranded, insulated wire not lighter than 18 AWG that is approved for marine use. It is recommended that insulated wire terminals, preferably ring type, be used on all connections to the compass.
3. Connect a wire to the stud marked "IGN" (ignition) and secure with a nut and lock washer. Connect opposite end to a 12 VDC circuit that is activated by the ignition switch. This lead should have a 1-Amp fuse (owner supplied).
4. Connect a wire to the stud marked "GND" (ground). Connect the opposite end to the boat's electrical ground, generally available in several locations at or near the instrument panel.
5. Connect a wire to the stud marked "LGT" (light) and secure with a nut and lock washer. Connect the opposite end to the positive "+" side of the boat's instrument lighting.
6. After mounting the sensor per section B, connect the sensor to the instrument by sliding the sensor cable connector into the rear of the instrument's case until the tab locks into place. To disconnect, depress the tab and pull straight out. Reconnect the battery.

Note

To change light bulbs, twist black socket assembly one-eighth turn counterclockwise until it will pull out of the instrument case. The bulb pulls out of the socket assembly. The M-2 uses one GE No.74 instrument bulb (Ritchie P/N MT-0445). The M-4 uses two GE No.194 instrument bulbs (Ritchie P/N MT-0446).

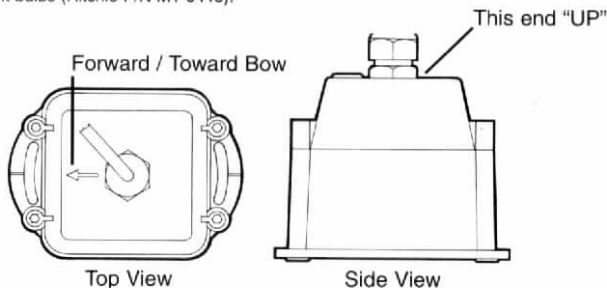

Sensor Mounting & Location

1. The sensor must be mounted on a flat level surface with the arrow located on the top of the sensor pointing in the direction of travel. Care should be taken in choosing a location for your sensor. The sensor should be located as far away from magnetic influences as possible.

Things to avoid:

Loudspeakers
Movable Metal Objects
Electric Motors
Appliances
Horns
Other Magnetic compasses

VHF Radios
Electronic equipment
Generators
Current carrying wires (High Amperage)
Battery banks

It is a good idea to test the operation of the sensor in the intended location prior to permanent mounting. Locations with heading errors greater than 25° before compensation are less desirable.

2. Connect the sensor to the instrument by sliding the sensor cable connector into the rear of the instrument's case until the tab locks into place. (To disconnect, depress the tab and pull straight out) Reconnect the battery. With the boat on several known headings, test the operation of the sensor in the intended location prior to permanent mounting. Locations with heading error greater than 25 before compensation are less desirable.

3. Fasten the Sensor as follows. Note: Ritchie does not provide mounting fasteners because of the variety of mounting locations and materials. However, you must always use non-ferrous fasteners such as high quality Stainless Steel, Silicon Bronze or Brass.

For this installation you will need: Two (2) non-ferrous #6 round head wood, sheet metal or machine screws of the appropriate length.



CAUTION

Never use IRON or CHROME PLATED FASTENERS.

A. Using the sensor housing as a template, mark the position of the two mounting slots. Then drill a hole into the center of each marked slot for your choice of fastener.

B. Mount the sensor housing using the fasteners selected. The slots on the sensor unit allow you to turn the sensor unit slightly to align it with the centerline of the boat.



CAUTION

Do not over tighten as to avoid cracking the plastic.

Compensation

Compensation is the procedure of adjusting a compass to compensate for errors in the indicated magnetic heading. These errors, commonly called deviations, are due to magnetic disturbances on the vessel. The sensor is equipped with automatic compensation software that will remove these deviations with the execution of the following simple procedure:

1. Perform the compensation in calm water.
2. Make sure power to the compass is "ON".
3. Ground the BROWN wire by placing the ring terminal on the ground stud at the back of the compass display.
4. The display will turn to "North" to indicate that the compensation is in progress.
5. Rotate the vessel through two (2) turns in either direction. The turn rate for optimum performance is approximately 1-2 turns per minute.
6. Upon completion the display will turn to "South" for approximately 7 seconds and then resume normal operation. This indicates that the compensation was successful.
7. Errors in the compensation procedure are indicated when the dial turns to "East" for approximately 7 seconds then resumes normal operation.

Sources for Compensation Error:

Rotating too fast	Sensor location
Changing the direction of rotation	Rough sea conditions

8. After completing the procedure, remove the BROWN wire from the ground stud and insulate the terminal so that it is not accidentally grounded during normal use.

Note

The compensation only needs to be performed once when the compass is installed. The compensation data is retained in memory even when power is removed from the unit.

Exception

If changes are made to the boat in the area around the sensor (equipment added or removed) that affect deviation, the sensor should be recompensated.

Warranty

We warrant all Ritchie Electronic Compasses and Sensors to be free of defects in workmanship or materials. If within two years of purchase date, these products fail to give satisfactory service they will be repaired or replaced without charge. This warranty does not cover breakage through accident or misuse. Replacement or repair will be made if the instrument is returned prepaid to E.S.Ritchie & Sons, Inc, 243 Oak Street, Pembroke, MA 02359.